

Channel Anchors

Channel Anchors for connecting panel to panel or panel to frame. Available w/ NC or Coil Nuts. Foam filled to prevent concrete intrusion.

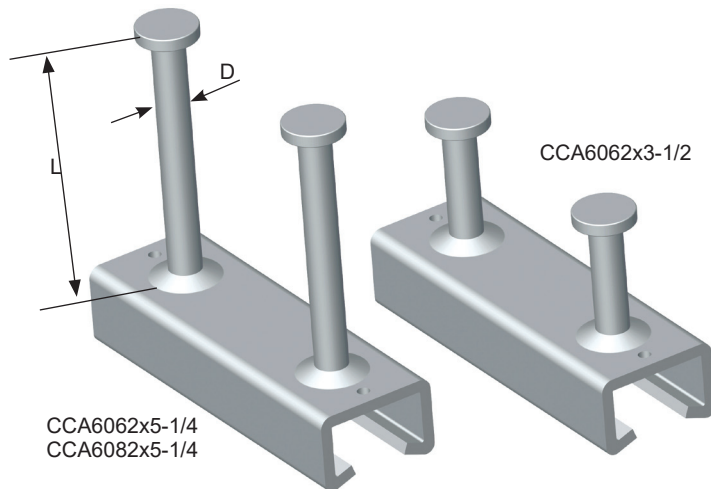

ITEM CODE	DESCRIPTION	CHANNEL BODY (MM)	LENGTH NOMINAL (ACTUAL IN INCH/MM)	DEPTH NOMINAL (ACTUAL IN INCH/MM)	STUD LENGTH (L)	STUD DIA. (D)	NO. OF STUDS
CCA6062x3-1/2	Channel Anchor 6"	53 x 33 x 5	6" (160)	3.5" (89)	2-1/4"	1/2"	2
CCA6062x5-1/4	Channel Anchor 6"	53 x 33 x 5	6" (160)	5.25" (133)	3-3/4"	1/2"	2
CCA6082x5-1/4	Channel Anchor 8"	53 x 33 x 5	8" (210)	5.25" (133)	3-3/4"	1/2"	2

ITEM CODE	DESCRIPTION	ALLOWABLE LOAD (LBS)*		SUGGESTED EDGE/END DISTANCE**	
		TENSION	SHEAR	TENSION	SHEAR
CCA6062x3-1/2	Channel Anchor 6"	4250	3600	5"	5"
CCA6062x5-1/4	Channel Anchor 6"	8000	6140	8"	8"
CCA6082x5-1/4	Channel Anchor 8"	8000	6550	8"	8"

* Safe working loads based on approximate 3:1 Safety Factor in 5,000 psi normal weight concrete.

** Suggested edge/end distance is from centerline of a stud to the nearest edge of concrete.

Note: Allowable load increases for wind loads have not been included in the channel anchor table.

Restraint Straps

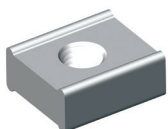
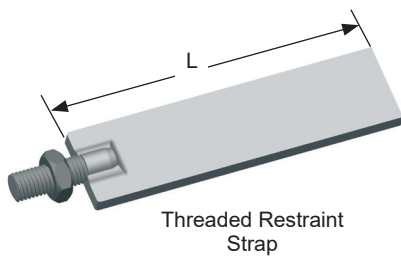
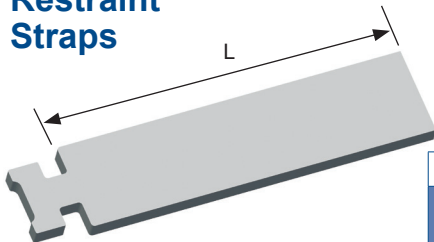

Channel Nut

ITEM CODE	DESCRIPTION	LENGTH (L)	WIDTH	THICK	ALLOWABLE LOAD (LBS)	
					TENSION	SHEAR
CCRS06	Restraint Strap 6"	6"	2"	3/8"	5000	4100
CCRS08	Restraint Strap 8"	8"	2"	3/8"	5000	4100
CCRS10	Restraint Strap 10"	10"	2"	3/8"	5000	4100
CCRS12	Restraint Strap 12"	12"	2"	3/8"	5000	4100
CCR06TS	Threaded Restraint Strap 6"	6"	2"	3/8"	7600	5000
CCR08TS	Threaded Restraint Strap 8"	8"	2"	3/8"	7600	5000
CCR10TS	Threaded Restraint Strap 10"	10"	2"	3/8"	7600	5000
CCR12TS	Threaded Restraint Strap 10"	12"	2"	3/8"	7600	5000
CCN075N	Channel Nut 3/4" NC Thread					
CCN075C	Channel Nut 3/4" Coil Thread					

Notes:

1. Strap capacity may not exceed the capacity of the anchor channel.
2. Connections that are displacement sensitive should use a threaded restraint strap with channel nut.
3. Strap capacities are at the face of the channel anchor. Load reductions due to eccentricities of the connection must be considered by the designer.